

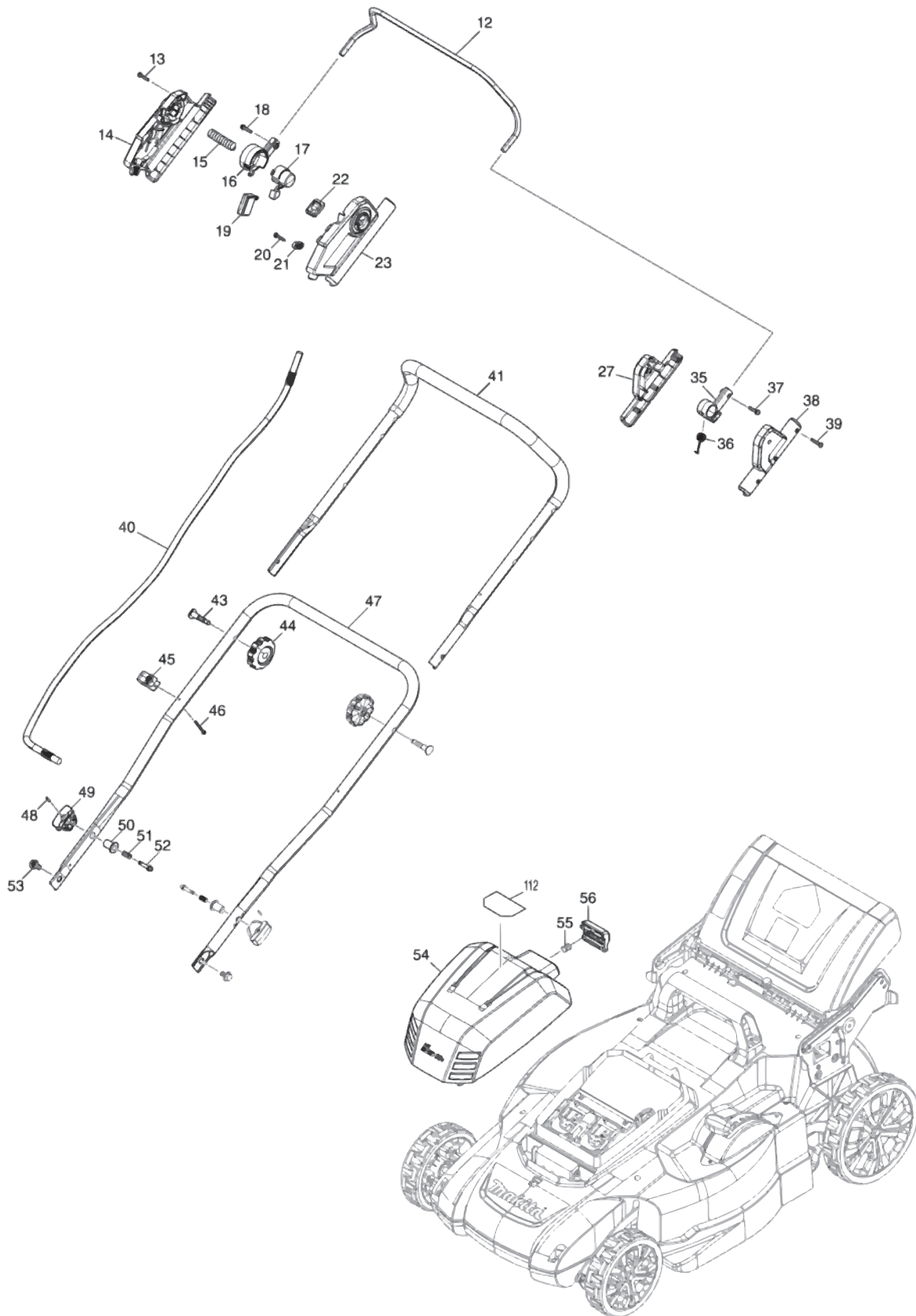

**XML13**



Products with multiple versions are listed in subsiding order with the newest version on top not indented.

Section	Fig. No.	Part No.	Description	XML13	Tech Bulletin	Notes
1	12	327424-8	SWITCH LEVER	1		
1	13	266424-2	TAPPING SCREW 4X20	7		
1	14	183V31-7	SWITCH BOX SET	1		
1	15	231227-3	COMPRESSION SPRING 15	1		
1	16	413A99-6	SWITCH LEVER SUPPORT R	1		
1		931102-0	HEX. NUT M4	1		Not Pictured
1	17	413B00-7	LOCK OFF BUTTON	1		
1	18	911138-5	P.H.SCREW M4X20 WITH WR	1		
1	19	651083-9	SWITCH C3XA-1PSPM	1		
1	20	266424-2	TAPPING SCREW 4X20	2		
1	21	687123-7	STRAIN RELIEF	1		
1	22	141H35-1	SWITCH CIRCUIT COMPLETE	1		
1	23	183V31-7	SWITCH BOX SET	1		
1	27	183U21-4	LEVER BOX SET	1		INC 38
1	35	459863-5	SWITCH LEVER SUPPORT L	1		
1		931102-0	HEX. NUT M4	1		
1	36	232575-3	TORSION SPRING 12	1		
1	37	911138-5	P.H.SCREW M4X20 WITH WR	1		
1	38	183U21-4	LEVER BOX SET	1		INC 27
1	39	266424-2	TAPPING SCREW 4X20	4		
1	40	699184-5	POWER SUPPLY CORD UNIT	1		
1	41	327871-3	HANDLE UPPER	1		
1	43	265C08-1	FLAT HEAD BOLT M8X50	2		
1	44	265C06-5	THUMB NUT M8	2		
1	45	413944-9	CLAMP	1		
1		931102-0	HEX. NUT M4	1		Not Pictured
1	46	911163-6	PAN HEAD SCREW M4X35	1		
1	47	122A73-0	HANDLE LOWER ASSEMBLY	1		INC 48-52
1	48	258004-8	SPRING PIN 2.5-16	2		
1	49	413943-1	KNOB	2		
1	50	327877-1	LOCK HOLDER	2		
1	51	234121-8	COMPRESSION SPRING 8	2		
1	52	327876-3	LOCK PIN	2		
1	53	265C07-3	HEX. BOLT M8	2		

Products with multiple versions are listed in subsiding order with the newest version on top not indented.

Section	Fig. No.	Part No.	Description	XML13	Tech Bulletin	Notes
1	54	141F57-9	BATTERY COVER COMPLETE	1		
1	55	231037-8	COMPRESSION SPRING 7	1		
1	56	413B03-1	LOCK LEVER	1		

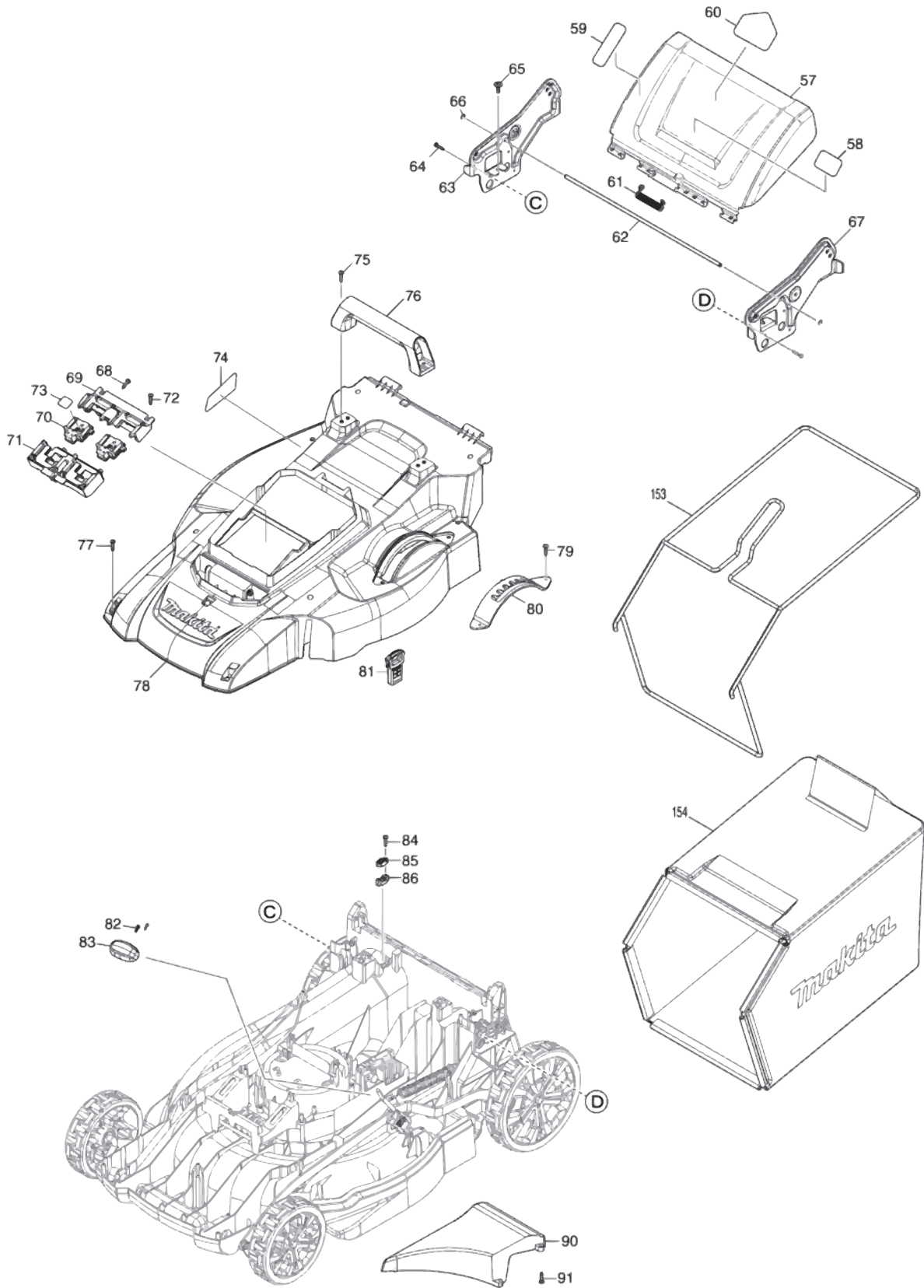

Products with multiple versions are listed in subsiding order with the newest version on top not indented.

Section	Fig. No.	Part No.	Description	XML13	Tech Bulletin	Notes
2	57	141S95-9	REAR FLAP COMPLETE	1		INC 58-60
2	61	232721-8	TORSION SPRING 8	1		
2	62	327874-7	ROD 6	1		
2	63	347867-8	HANDLE BRACKET R	1		
2	64	266553-1	TAPPING SCREW 5X30	6		
2	65	265C05-7	TAPPING SCREW FRANGE 5X20	2		
2	66	259084-7	STOP RING (EXT) E-5	2		
2	67	347866-0	HANDLE BRACKET L	1		
2	68	266424-2	TAPPING SCREW 4X20	3		
2	69	183N35-1	TERMINAL HOUSING SET	1		INC 71
2		263005-3	RUBBER PIN 6	4		Not Pictured
2	70	644809-6	TERMINAL	2		
2	71	183N35-1	TERMINAL HOUSING SET	1		INC 69
2		263005-3	RUBBER PIN 6	4		Not Pictured
2	72	266424-2	TAPPING SCREW 4X20	3		
2	73	8589T5-6	XML13 SERIAL NO. LABEL	1		
2	74	8589T4-8	XML13 NAME PLATE	1		
2	75	266424-2	TAPPING SCREW 4X20	4		
2	76	413938-4	REAR GRIP	1		
2	77	266424-2	TAPPING SCREW 4X20	11		
2	78	141S93-3	COWLING COMPLETE	1		
2		422789-4	SPONGE SEAL	1		Not Pictured
2	79	266424-2	TAPPING SCREW 4X20	2		
2	80	162B97-0	HEIGHT ADJUST PLATE US	1		
2	81	643535-4	KEY	1		
2	82	265C97-6	+ PAN HEAD SCREW M3X12 WITH WR	2		
2	83	413939-2	HEIGHT ADJUST LEVER GRIP	1		
2	84	266424-2	TAPPING SCREW 4X20	2		
2	85	687123-7	STRAIN RELIEF	1		
2	86	687051-6	STRAIN RELIEF	1		
2	90	413924-5	DECK REAR COVER	1		
2	91	266424-2	TAPPING SCREW 4X20	4		
2	153	162C44-7	GRASS CATCHER BRACKET	1		
2	154	162C65-9	GRASS CATCHER	1		

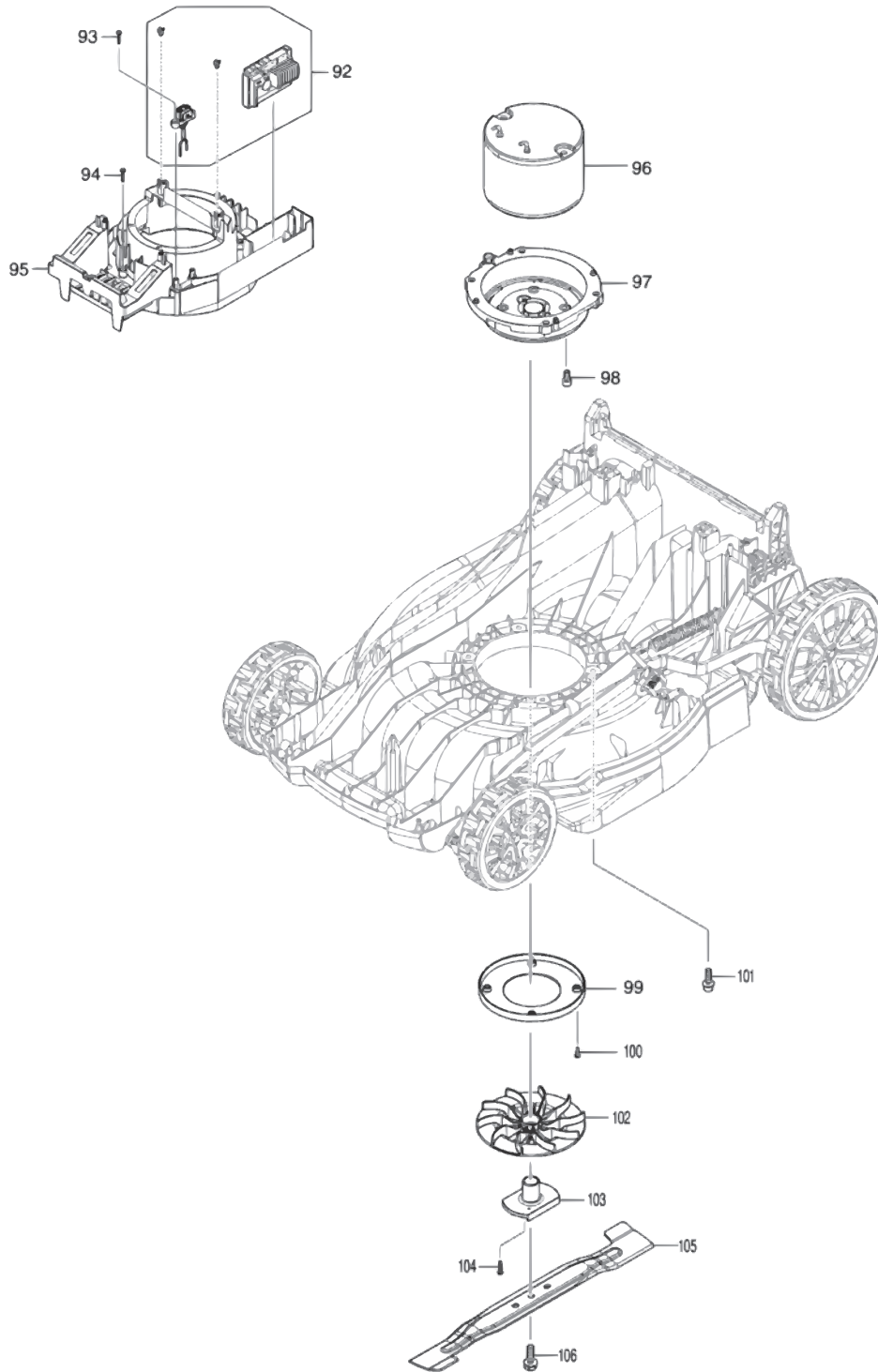

Products with multiple versions are listed in subsiding order with the newest version on top not indented.

Section	Fig. No.	Part No.	Description	XML13	Tech Bulletin	Notes
3	92	620G78-5	CONTROLLER	1		
3	93	266424-2	TAPPING SCREW 4X20	2		
3	94	266424-2	TAPPING SCREW 4X20	4		
3	95	413B05-7	MOTOR COVER	1		
3	96	629A88-3	DC MOTOR	1		
3	97	141H61-0	MOTOR BRACKET COMPLETE	1		
3	98	922422-3	HEX. SOCKET HEAD BOLT M8X16	4		
3	99	459853-8	BAFFLE PLATE	1		
3	100	266385-6	TAPPING SCREW 4X14	4		
3	101	265C22-7	H.S.H.BOLT M8X30 WITH WG	4		
3	102	240229-8	FAN 170	1		
3	103	313393-9	BLADE SUPPORT 480	1		
3	104	266424-2	TAPPING SCREW 4X20	2		
3	105	191V97-3	BLADE 480 SET	1		
3	106	265A69-9	HEX. BOLT M10X35 WITH WG	1		



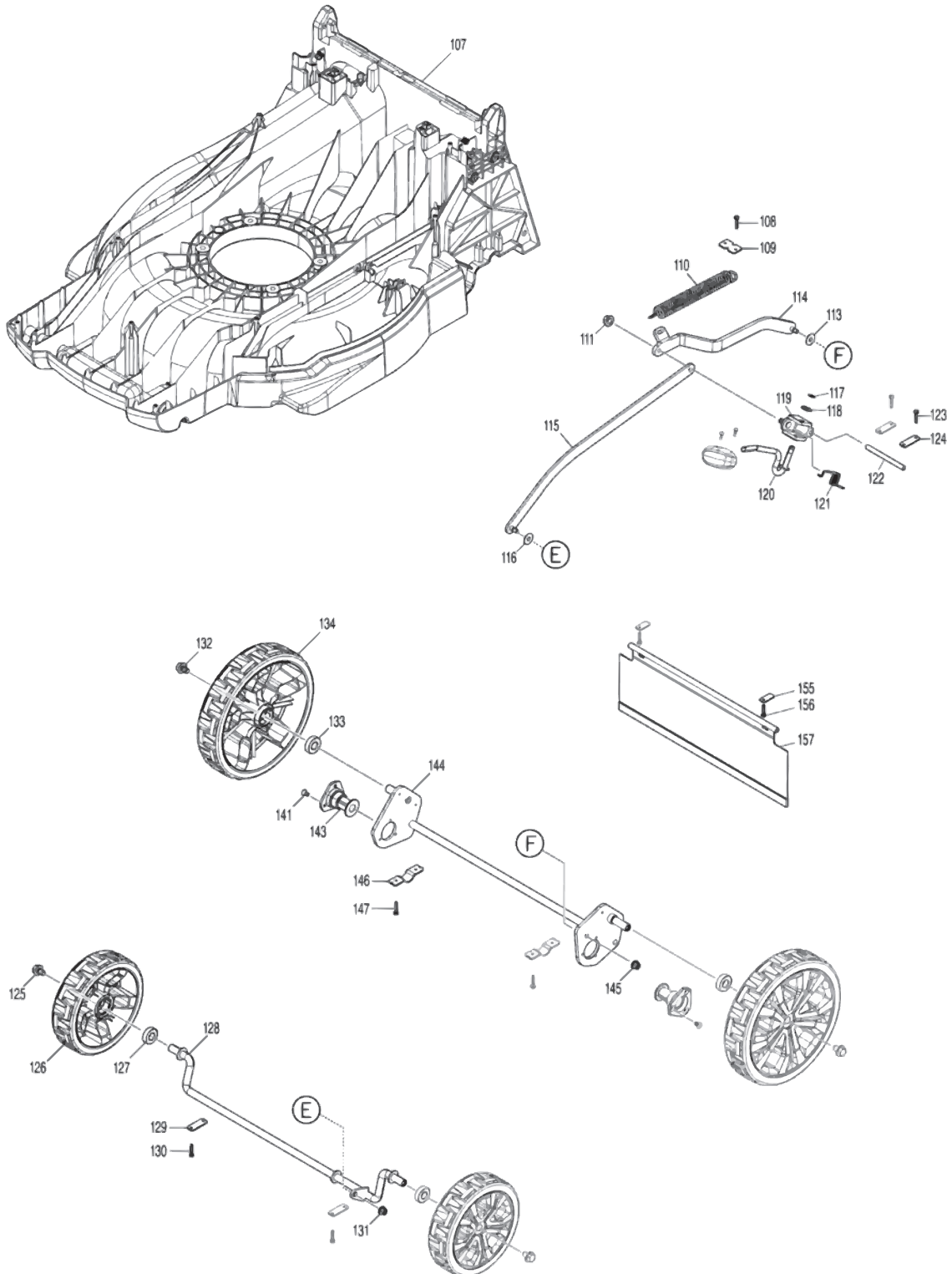

Products with multiple versions are listed in subsiding order with the newest version on top not indented.

Section	Fig. No.	Part No.	Description	XML13	Tech Bulletin	Notes
4	107	413A62-9	DECK	1		
4	108	266424-2	TAPPING SCREW 4X20	2		
4	109	347870-9	HOOK PLATE	1		
4	110	232717-9	TENSION SPRING 17	1		
4	111	252301-4	HEX. FLANGE LOCK NUT M6-10	1		
4	113	253731-2	FLAT WASHER 8	1		
4	114	347873-3	CONNECTING ROD R	1		
4	115	347872-5	CONNECTING ROD F	1		
4	116	253731-2	FLAT WASHER 8	1		
4	117	259085-5	STOP RING (EXT)E-6	1		
4	118	267281-1	FLAT WASHER 8	1		
4	119	313389-0	ROD HOLDER	1		
4	120	327872-1	HEIGHT ADJUST LEVER	1		
4	121	232715-3	TORSION SPRING 9	1		
4	122	327873-9	ROD 7	1		
4	123	266424-2	TAPPING SCREW 4X20	4		
4	124	347869-4	PLATE	2		
4	125	265324-3	HEX. FLANGE HEAD BOLT M8X12	2		
4	126	141E34-5	TIRE 180 COMPLETE	2		
4	127	210163-6	BALL BEARING 6001DDW	2		
4	128	162991-4	FRONT SHAFT	1		
4	129	347869-4	PLATE	2		
4	130	266424-2	TAPPING SCREW 4X20	4		
4	131	252301-4	HEX. FLANGE LOCK NUT M6-10	1		
4	132	265324-3	HEX. FLANGE HEAD BOLT M8X12	2		
4	133	210163-6	BALL BEARING 6001DDW	2		
4	134	141E35-3	TIRE 230 COMPLETE	2		
4	141	251951-2	HEX. SOCKET HEAD BOLT M5X10	6		
4	143	313390-5	REAR SHAFT HOLDER	2		
4	144	162992-2	REAR SHAFT	1		
4	145	252301-4	HEX. FLANGE LOCK NUT M6-10	1		
4	146	347865-2	CLAMP 19	2		

Products with multiple versions are listed in subsiding order with the newest version on top not indented.

Section	Fig. No.	Part No.	Description	XML13	Tech Bulletin	Notes
4	147	266553-1	TAPPING SCREW 5X30	4		
4	155	346545-7	PLATE	2		
4	156	266424-2	TAPPING SCREW 4X20	2		
4	157	422788-6	PROTECTIVE SHIELD	1		